



Reference Jubilee

User manual



Pic. similar

User manual

Dear **Clearaudio** customer,

Many thanks for choosing **Clearaudio's Reference Jubilee** turntable, a high quality product made in Germany by **Clearaudio Electronic GmbH**.

This limited edition turntable, created to mark the occasion of the company's 40th anniversary, combines a raft of design highlights from recent decades with some exciting new technical developments.

Please read this instruction manual carefully to avoid any potential damage or loss of warranty.

The manual will help to ensure an easy setup, and enable the greatest listening pleasure for years to come.

Thank you for your confidence in us and we hope you enjoy your new **Clearaudio Reference Jubilee** turntable.

Clearaudio Electronic GmbH

This section must be read before any connection is made to the mains supply.



Loving music

User manual



Important Safety Instructions



1. General Information

- Read these instructions and keep them for future reference. Follow all instructions carefully.
- Not suitable for children under 6 years! The product may contain small parts that could be swallowed. Risk of suffocation from plastic films and small parts. Keep plastic films, bags, straps, etc., out of reach of children, as they pose a suffocation hazard. Children may strangle themselves with cables. Keep cables out of reach of children.
- Inspect the device for damage before use. If the device is damaged, do not connect it to the power supply! Repairs or maintenance are required if any damage is detected, such as to the power cable or plug, if liquid or objects have entered the device, if it has been exposed to rain or moisture, is not functioning properly, or has been dropped. Contact your retailer for inspection.
- Manual Operation Required: The turntable does not have an automatic stop function. Once the run-out groove is reached, lift the tonearm from the record using the manual lift and turn off the turntable manually.
- **Specific Instructions for Clearaudio Concept Signature and Celebrity "Al Di Meola" Models:**
Restart: If the device becomes unresponsive, restore normal operation by turning it off and on again using the power switch on the back.

2. Intended Use

The turntable is designed for playing vinyl records. Intended use requires compliance with the operating instructions provided. The power supply must be used only within its specified technical parameters. Any other use or modification of the power supply is considered improper.

3. Installation Location

- Avoid locations with direct sunlight, temperature fluctuations, or high humidity. Do not place the device near heaters, heat lamps, or other devices that generate heat. The turntable is intended for use in heated rooms and should only be placed on flat surfaces.
- Never block ventilation slots or cover the device with fabric or similar materials. Do not place objects on top of the device.
- Installing the device in closed cabinets or similar furniture is not permitted.
- Choose a location near a wall outlet to ensure the plug is always easily accessible.
- Never operate electrical devices near water.

4. Connections

- Never bypass the safety features of polarized or grounded plugs. Polarized plugs have two blades, one wider than the other. Grounded plugs have two blades and a third grounding prong. These features are designed for safety. If your outlet is incompatible with the plug, consult an electrician to replace the outlet.
- Ensure that cables are not stepped on, pinched, or subjected to strain near plugs, outlets, or where they exit the device. Regularly inspect cables for damage to their insulation. Replace damaged cables immediately with professional assistance.
- A small standby current is drawn even when the power or standby/on switch is in the "off" position.
- Always unplug the device by pulling the plug, not the cord.

5. Maintenance

- Disconnect the power supply from the mains if the device will not be used for an extended period.
- Use only specialized acrylic glass cleaners for cleaning acrylic parts. Never use alcohol-based liquids (e.g., ethanol or spirits) to avoid surface damage. Avoid aggressive cleaning agents. Do not use dry cloths, as they can cause static buildup. Suitable cleaning and care products from Clearaudio are available at www.analogshop.de or from authorized retailers. Lubricate the turntable bearing approximately every two years with the included bearing oil, using 1-2 drops in the bearing housing.
- Electrical devices contain magnetic storage components. Avoid placing external magnets near the device to prevent damage to magnetic components.

6. Health Warnings

- Prolonged exposure to high volume levels can cause hearing damage. Use high volumes responsibly.
- Heat Development: Exercise caution when touching the device, as the housing may become warm during operation.
- Risk of injury during setup due to heavy components (e.g., pinching fingers while placing the turntable platter).
- Beware of sharp objects that could cause injury.

7. Disclaimer of Liability

Use only accessories approved by the manufacturer. Warranty claims will be void if damage is caused by failure to follow the instructions in the manual. The manufacturer assumes no liability for consequential damages.

Liability Disclaimer: Clearaudio assumes no liability for damage to sound carriers caused by improper handling!

8. Service

- Do not open the device housing to access internal electronics, as it contains no user-serviceable components. This action may void the warranty. Repairs should only be performed by qualified personnel.
- During the warranty period, repairs may only be carried out by the manufacturer. Otherwise, the warranty will be void.
- Service for all Clearaudio products should be conducted exclusively through authorized dealers. If service is needed, return the product to Clearaudio via your retailer.
- In case of malfunctions, contact the retailer where the device was purchased. Do not use the product until it has been repaired.

9. Transport

- Always use the original packaging when transporting the Clearaudio turntable. Pack the device as it was delivered to ensure safe transport. When packing, reverse the setup process as described in the setup and operation instructions.
- Secure the turntable platter and tonearm with adhesive tape for transport.
- Ensure that the platter is packed with the milled side facing up in the bottom packaging layer and that the feet are screwed back into place.

Clearaudio assumes no liability for transport damage caused by improper packing.

10. CE Compliance

This product meets the requirements of European directives and other Commission regulations.

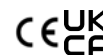

11. Disposal

For customers in Europe: Disposal of old electrical and electronic devices, batteries, and accumulators:

 a) If a product, its packaging, and/or accompanying documentation is marked with the symbol of a crossed-out waste bin, this product is subject to European directives and national laws implementing these directives.

b) These directives and laws stipulate that electrical and electronic waste as well as batteries and accumulators must not be disposed of with household waste (residual waste). To ensure proper disposal, processing, and recycling, you are required to dispose of old devices and discharged batteries/accumulators at designated collection points.

c) By properly disposing of such devices, batteries, and accumulators, you contribute to the conservation of valuable raw materials and prevent potentially harmful effects on public health and the environment that can result from improper waste disposal. Disposal is free of charge for you.

d) For more information on the collection and recycling of old devices, batteries, and accumulators, please contact your local municipal office, the waste disposal company responsible for you, or the point of sale where you purchased the product.

Contents

1. Package contents overview	5
2. List of components	6 - 7
3. Set-up	8 - 13
4. Mounting of tonearm and cartridge	13 - 14
5. Initial operation and calibration of the speed	14 - 15
6. Troubleshooting	16 - 17
7. Technical data	18
Warranty information	20 - 21
Stroboscope Testrecord User manual	22 - 23

1. Package contents overview

Clearaudio has developed a special, secure packing for your *Reference Jubilee* turntable to ensure a safe transportation.

Please keep this original packing, if you need to ship the turntable.

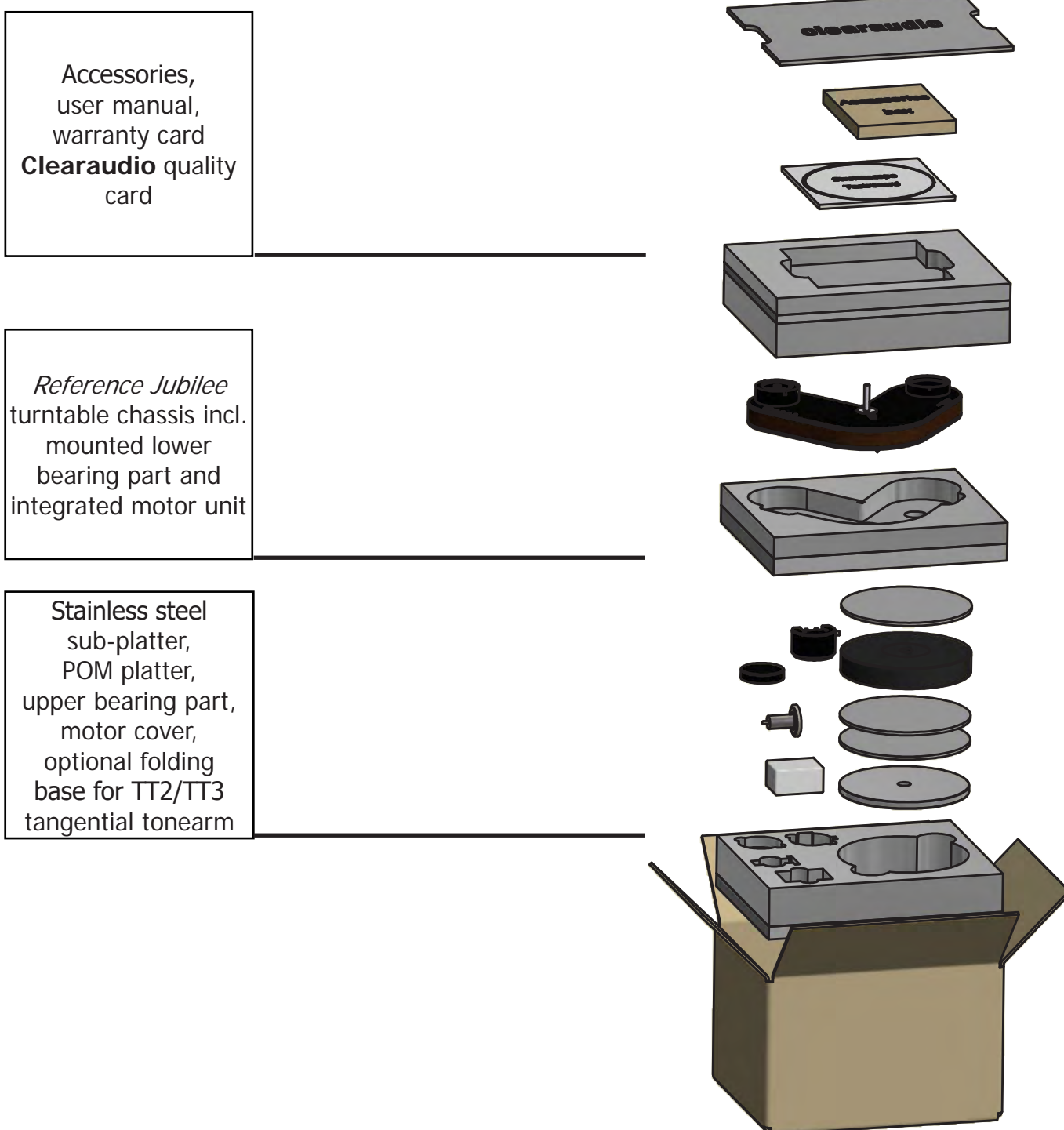

Pic. 1: Package contents overview

2. List of components

Please use the list below to check that all components of your newly purchased **Clearaudio Reference Jubilee** turntable have been correctly supplied.

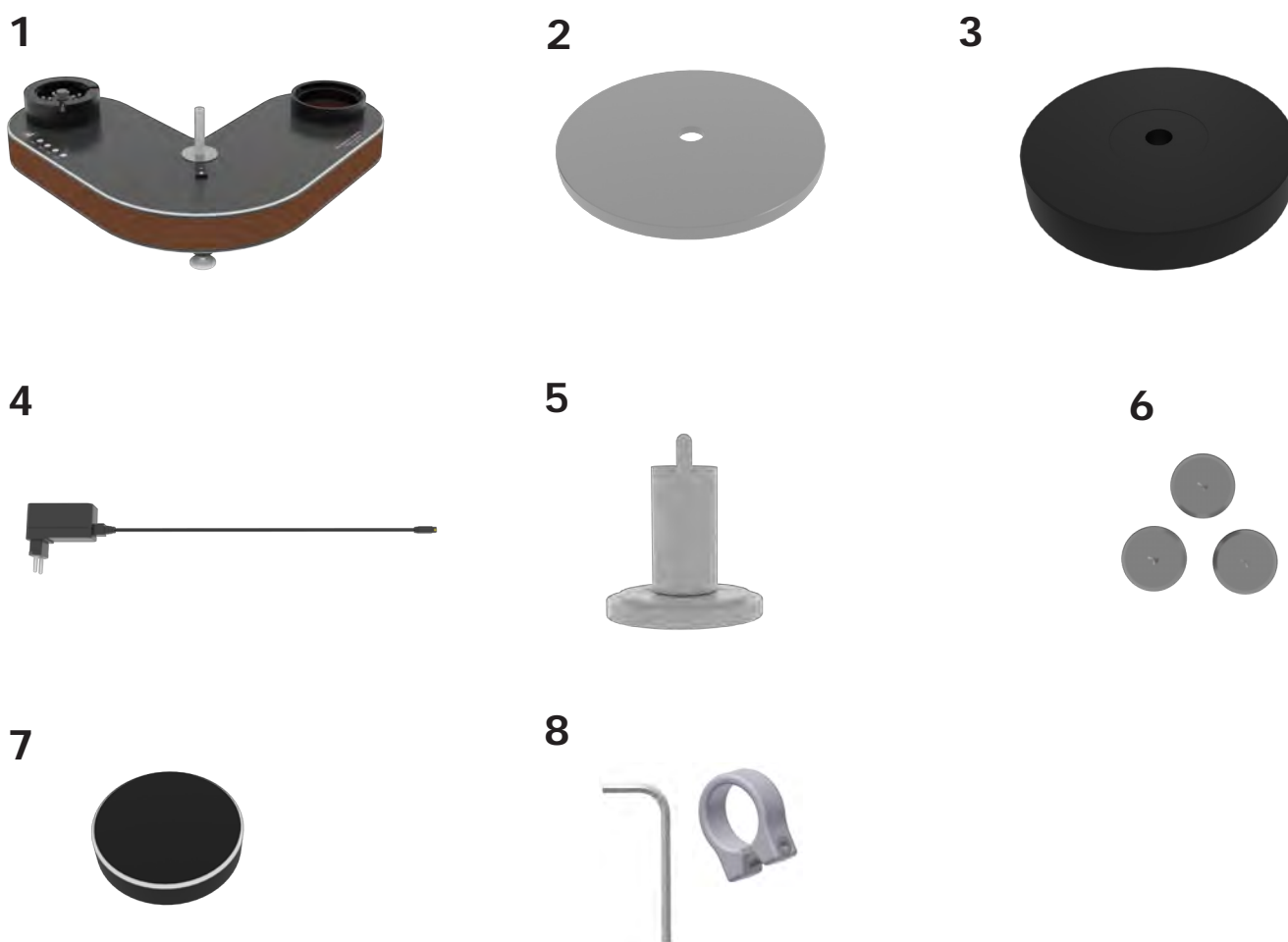

Pic. 2: List of components

1.	Turntable chassis with incl. lower bearing part	5.	Magnet bearing (upper part)
2.	Stainless steel sub-platter	6.	3x flat pad
3.	POM turntable platter	7.	Motor cover
4.	Power supply	8.	Mounting clip for stainless steel sub-platter and hex wrench

User manual

Components list (continued)

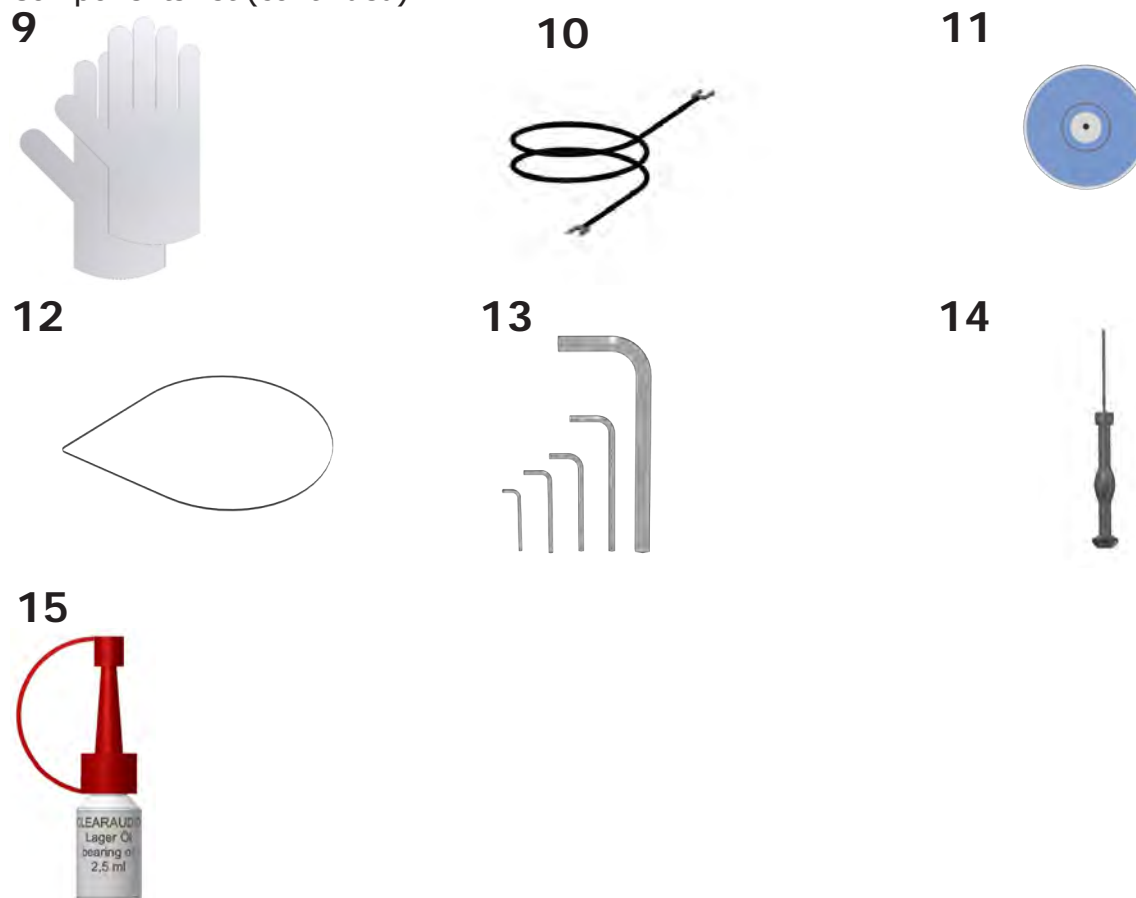

Pic. 2.1: List of components (continued)

9.	1 pair of white gloves	14.	Screwdriver
10.	Grounding wire for the turntable	15.	Bearing oil for occasional use
11.	Level gauge for turntable alignment	16.	Not shown: Tonearm base (depending on the tonearm ordered, this may be included in delivery or pre-mounted)
12.	1x flat belt	17.	Not shown: Warranty card, Clearaudio quality card, return delivery note
13.	5x hex wrench Sizes 1.5; 2; 2.5; 3; 7	18.	Not shown: User manual

IMPORTANT NOTICE:

Please double check the tightness of all bolts, hardware and mounting pods, as temperature fluctuations during transit may have caused the hardware to become loose.

3. Set-up

The set-up of the *Reference Jubilee* turntable is easy as the turntable chassis is pre-assembled and has been tested at the factory.

Please use the white gloves enclosed in order to avoid scratches or unwanted fingerprints (platter).

The *Reference Jubilee* turntable requires a space for setup of at least 495 x 343mm (19.49 inch x 13.50 inch).

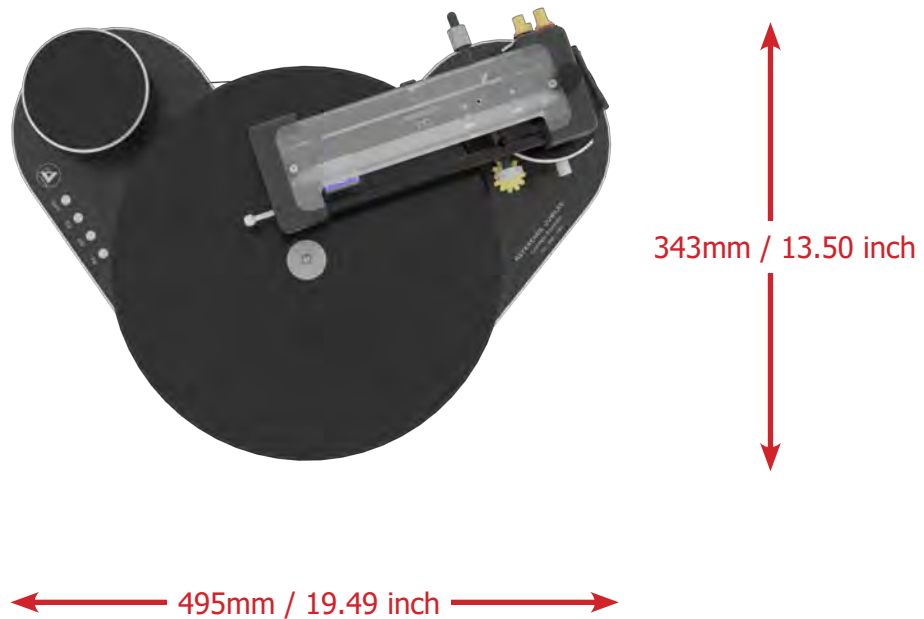

Pic. 3: Required set-up space *Reference Jubilee*

Please follow the instructions step by step:

3.1)

The top packaging level contains all accessoires. Please take out the three black flat pads. Place these flat pads on your hifi-rack or another suitable base, where the final position of your *Reference Jubilee* turntable will be.

3.2)

Remove the entire upper packaging level from the box. Take out the *Reference Jubilee* turntable body and place its pre-assembled feet (spikes) on the previously positioned flat pads.

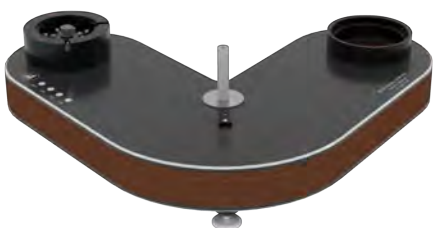

Pic. 4: *Reference Jubilee* delivery condition

User manual

3.3)

To avoid hum noises we recommend to ground the bearing.
To do so, attach the grounding wire supplied to the bearing cap with the screw provided.

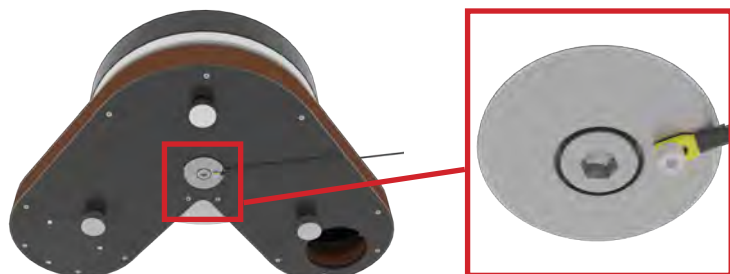

Pic. 5: Grounding the *Reference Jubilee*

3.4)

Remove the protective security tape from the bearing housing.
Place two drops of the synthetic bearing oil on the ceramic bearing shaft (also available at www.analogshop.de, Art. No. AC068).



Pic. 6: Oiling the bearing shaft

3.5

Remove the protective film from the sensor mounted in the turntable chassis.
Please remove the protective film extreme carefully and avoid any soiling and scratches.

3.6.

Using both hands, carefully take the stainless steel sub-platter out of the box.
Carefully remove the protective film from the sensor ring on the underside of the sub-platter.
Again, please remove the protective film extremely carefully to avoid any soiling or scratches.

Carefully slide the upper part of the bearing through the opening of the sub-platter and fix the upper part of the bearing using the mounting clip supplied. The lower side of the platter with the sensor ring must point downwards.

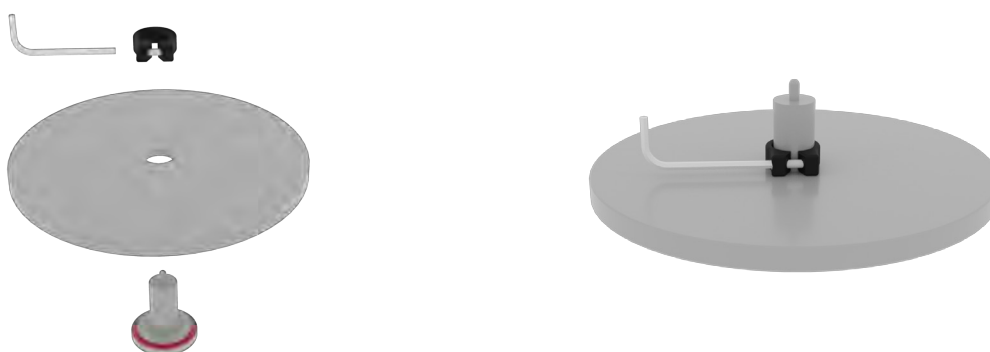

Pic. 7: Connection of sub-platter and bearing

3.7)

Place the sub-platter carefully and slowly on the axis of the pre-mounted magnet bearing on the turntable chassis.

Please proceed very carefully!

Make sure that the platter is positioned straight and level, so that it does not tilt and damage the bearing while it is being placed!

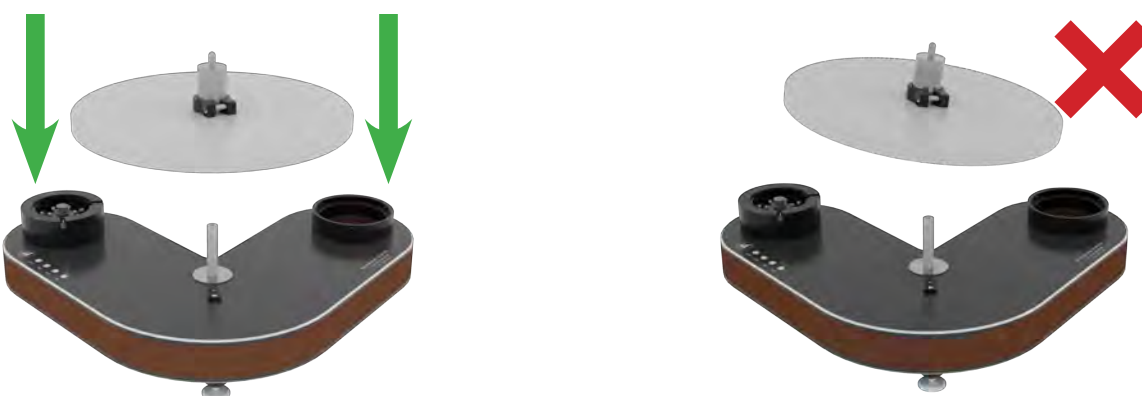

Pic. 8: Placing the stainless steel sub-platter

3.8)

Now you can remove the mounting clip with the hex wrench provided.

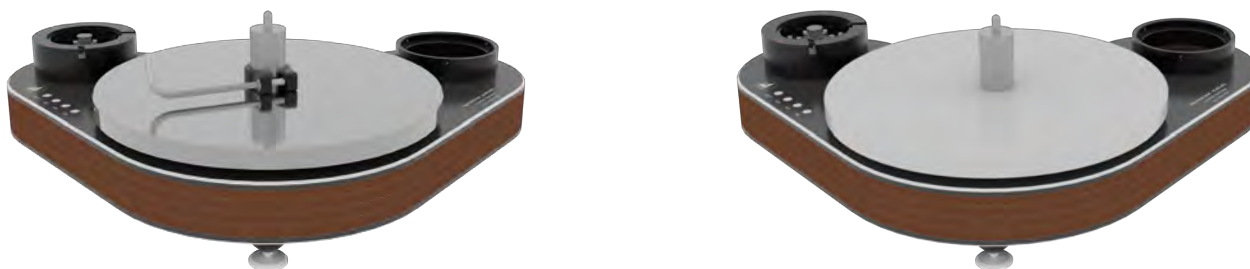

Pic. 9: Removing the mounting clip

User manual

3.9)

Take the second platter (made of POM) out of the packaging and slide it onto the bearing. The larger recess (for the record label) on the platter should point upwards.

Please ensure that the platter is at least room temperature (approx. 20°C) while mounting to avoid any damage to the bearing.

Avoid major side forces to avoid any damages to the ceramic bearing!



Pic. 10: Mounting the POM platter

3.10)

Place the flat belt around the platter and the motor pulley.

Make sure that the belt runs in the cutouts of the motor housing.

To ensure that the belt does not come off when it is started up for the first time, we recommend holding the flat belt in position with your finger and turning the platter by hand until the belt remains in the correct position.



Pic. 11: Mounting the belt

Close the motor unit with the supplied motor cover.
Make sure that magnets are on top of each other.



Pic. 12: Placing the motor cover

3.11)

The following final adjustment is very important:

Please check, using the bubble level gauge, that your *Reference Jubilee* turntable is in a level position. You can adjust each of the turntable's feet to achieve this.

You will only get the best results with your *Reference Jubilee* turntable if it is in a level position.



Pic. 13 a: Alignment of the turntable

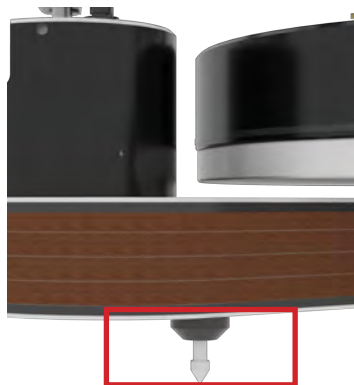

Pic. 13 b: Adjustment of the turntable feet

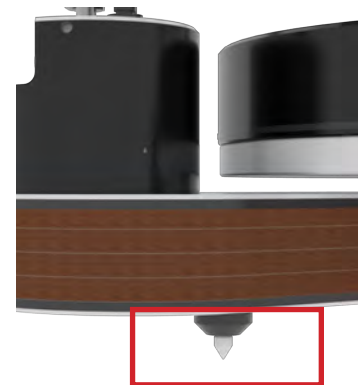

3.12)

Please connect the mains plug to your power supply.



Pic. 14: Connection power supply and motor

4. Mounting of tonearm and cartridge

4.1)

When ordering the *Reference Jubilee* turntable in combination with a **Clearaudio** radial tonearm, the required tonearm base is already pre-assembled. For final assembly and adjustment of the tonearm base and tonearm, proceed as described in the tonearm user manual.

4.2)

When ordering the *Reference Jubilee* turntable in combination with a **Clearaudio** tangential tonearm, you will find the required folding base in the bottom packaging layer. Place the folding base on the opening provided, making sure that the cut-out points outwards. Then fix the three grub screws of the tonearm base mount to continue the tonearm mounting.



Pic. 15: Mounting the folding base

For the final assembly and adjustment of the tonearm, proceed as described in the relevant tonearm user manual.

Please note that you will need to slightly loosen the grub screws of the tonearm base mount for setting the tangential alignment (TT2 / TT3 user manual, point 7.3).

4.3)

For mounting and adjustment of the cartridge, please proceed as described in the relevant cartridge user manual.

Clearaudio offers a selection of professional setting tools for your turntable. Please contact your dealer / distributor for more information.

5. Initial start and calibration of the speed

5.1)

To start operating the turntable at the desired speed, press the relevant labelled button on the motor housing.

We recommend letting the turntable run-in for about 15-30 minutes when using it for the first time.



Pic. 16: Control panel *Reference Jubilee*

5.2)

Thanks to the newly developed motor control, the *Reference Jubilee* turntable calibrates itself automatically in order to always maintain the perfect speed.

However, manual calibration is also possible. We recommend this if the turntable has not been in use for a long time, if parts (e.g. the belt) have been replaced, or if the turntable is set up again after moving.

If you would like to start the calibration manually, please proceed as follows to recalibrate all three speeds. This process takes about 5 minutes.

Hold down the OFF button until the 33 button flashes and the platter begins to turn.

> The speed 33rpm is now calibrating.

When the 33 button lights up continuously and the 45 button starts to flash.

> The 33rpm speed is calibrated and the turntable is now calibrating 45rpm.

When the 45 button lights up continuously and the 78 button starts to flash.

> The 45rpm speed is calibrated and the turntable is now calibrating 78rpm.

The calibration for 78rpm is complete when all 3 speed options and the OFF button flash alternately.

A longer press on OFF (speed options stop flashing) saves the calibration of all three speeds.

To stop the calibration process you can press any button.



5.3)

In order to adapt the standard speed to your own preferences, you can also adjust the basic speeds manually.

To adjust the speed for example for 33 1/3rpm, hold down the button for 33 until it flashes.

The remaining buttons now function as + and - to gradually reduce or increase the speed. The respective key assignment can be found in the table below.

Speed	-	+
33 1/3rpm	45rpm	78rpm
45rpm	33 1/3rpm	78rpm
78rpm	33 1/3rpm	45rpm

If you want to reset this setting, proceed as described in point 5.2.

5. Troubleshooting

If you have a problem with your *Reference Jubilee* turntable, first check the possible causes to rule out incorrect operation.

If the error persists, please contact your dealer!

Never try to open the device and/or repair it yourself, this will void the warranty!

Error	Cause	Measure
Device does not work	Is the power cord plugged in?	Check the connection.
No sound	The tonearm and phono stage are not properly connected.	Check the cable connection between the tonearm and the phono stage.
	Is the amp turned on?	Check the power supply to the amplifier.
	The volume on the amplifier/ loudspeaker is set too low or on „mute“.	Check the volume settings.
	Is the cartridge protective cap still attached?	Remove the cartridge's protective cap.
	Is the tonearm in the raised position?	Lower the tonearm into the lead-in groove.
	Is the stylus damaged?	Check the stylus and have the cartridge checked by a specialist if necessary.
Bad sound / noise	Is the record or the stylus dirty or damaged?	Clean the record / or the cartridge. Clearaudio offers many helpful accessories for care and cleaning. In the event of damage, we recommend an assessment by a specialist and, if necessary, an exchange.
	Is the cartridge properly mounted into the tonearm?	Check the installation using the relevant user manual and correct them if necessary.
	Has the tracking force been set too high?	Adjust the tracking force.
	Is the correct operating mode (MM / MC) set on the amplifier?	Check the settings of your phono stage.
	The pre/amp does not have enough gain.	Check the settings of your phono stage.
	Pre/amp is mismatched.	Swap the plugs of the turntable that are connected to the left and right outputs.



Needle bounces or slides across record	Is the record or the stylus dirty or damaged?	Clean the record / or the cartridge. Clearaudio offers many helpful accessories for care and cleaning. In the event of damage, we recommend an assessment by a specialist and, if necessary, an exchange.
	Has the tracking force been set too high?	Adjust the tracking force.
	Is the record deformed or scratched?	Use a record clamp or replace the record.
	Is the turntable level?	Check the alignment of the turntable and adjust if necessary.
Platter does not turn	Is the drive belt properly attached?	Check the position of the drive belt.
	Is the power cord connected properly?	Check the connection.
	No speed was selected / speed selection in position „0“/“OFF“.	Select a speed and start the turntable.
Noisy sound	Is the drive belt properly attached?	Check the position of the drive belt. Is it too loose and needs to be changed?
Humming noises	Contact problems with the signal connections (e.g. cinch plugs, adapters for extensions)	Check all connections; reduce the level on the (pre-)amplifier to a low volume for acoustic checking of gross errors.
	Metal housing acts as an antenna and catches hum.	It can be helpful for conductivity to connect the metal parts of the turntable to the ground of the (phono) preamplifier. The turntable provides a grounding terminal for this purpose. Use a sufficiently thick wire to establish the ground connection.
	The pickup pins are mixed up, not connected correctly or defective.	Check the pin assignment of the pickup.
The music doesn't sound like usual	Wrong speed selected.	Check the record for recommended speed. There are also records in LP format (30 cm) that have to be played at 45 rpm ("maxi singles") and small records in single format (17 cm) that have to be played at 33 rpm (so-called "EP's").
	The turntable is spinning too fast/too slow.	Adjust the speed according to the operating instructions.

7. Technical data

Construction details:	<ul style="list-style-type: none"> - Resonance-optimised chassis shape - Made of laminated wood and aluminium - All turntable feet are fine adjustable - Optical Speed Control (OSC) - IMS – Innovative Motor Suspension (Suspension design of the motor using 18 O-rings)
Speed options:	33 1/3, 45, 78rpm
Drive unit:	<ul style="list-style-type: none"> - High torque 24V DC motor with belt drive - Fully automatic self-calibration of the speed by a push of a button - Hybrid engine control: A high resolution 12 bit digital-to-analog converter (DAC) generates a motor reference voltage, which is fed into the purely analog motor control. Automatic compensation of friction and temperature changes on the platter bearings and belts. The speed remains in the perfect range at all times.
Bearing:	Inverted bearing in lower drive platter, sintered bronze bushing, incl. Clearaudio CMB ceramic magnetic bearing in main platter
Platter:	50mm / 1.97 inch main platter, made out of synthetic material with high-density and excellent dimension. // 15mm / 0.59 inch stability, precision CNC machined surface, solid stainless steel sub-platter, dynamically balanced.
Speed accuracy (measured):	± 0.05%
Power consumption:	Max. consumption: 5.0 watts Consumption in operation: 2.1 watts Off mode: 1.8 watts
Total weight:	approx. 22kg (without tonearm and power supply)
Dimensions (W/D/H):	Approx. 495 x 343 x 180mm (with tonarm base, without tonearm)
Dimensions (W/D/H):	Approx. 19.49 x 13.50 x 7.09 inches (with tonarm base, without tonearm)
Manufacturer warranty:	5 years*

* Provided that the warranty card is correctly completed and returned to **Clearaudio**, or your product is registered online at <https://clearaudio.de/en/service/registration.php>, within 14 days of purchase.



The full, extended warranty period for the *Reference Jubilee* turntable is 5 years.

To receive this full **Clearaudio** warranty, you must either complete and return the relevant section of the warranty registration card to **Clearaudio**, or register your product online at <https://clearaudio.de/en/service/registration.php>, within 14 days of purchase.

Otherwise only the legal warranty can be considered.

The full 5 year warranty can only be honoured if the product is returned in its original packing.

ENGLISH WARRANTY

For warranty information, contact your local **Clearaudio** distributor.

RETAIN YOUR PURCHASE RECEIPT

Your purchase receipt is your permanent record of a valuable purchase. It should be kept in a safe place to be referred to as necessary for insurance purposes or when corresponding with **Clearaudio**.

IMPORTANT

When seeking warranty service, it is the responsibility of the consumer to establish proof and date of purchase.

Your purchase receipt or invoice is adequate for such proof.

FOR U.K. ONLY

This undertaking is in addition to a consumer's statutory rights and does not affect those rights in any way.

FRANÇAIS GARANTIE

Pour des informations sur la garantie, contacter le distributeur local **Clearaudio**.

CONSERVER L'ATTESTATION D'ACHAT

L'attestation d'achat est la preuve permanente d'un achat de valeur. La conserver en lieu sûr pour s'y reporter aux fins d'obtention d'une couverture d'assurance ou dans le cadre de correspondances avec **Clearaudio**.

IMPORTANT

Pour l'obtention d'un service couvert par la garantie, il incombe au client d'établir la preuve de l'achat et d'en corroborer la date. Le reçu ou la facture constituent des preuves suffisantes.

DEUTSCH GARANTIE

Bei Garantiefragen wenden Sie sich bitte zunächst an Ihren **Clearaudio** Händler. Heben Sie Ihren Kaufbeleg gut auf.

WICHTIG!

Die Angaben auf Ihrer Quittung erlauben uns die Identifizierung Ihres Gerätes und belegen mit dem Kaufdatum die Dauer Ihrer Garantie-Ansprüche. Für Serviceleistungen benötigen wir stets die Gerätenummer. Diese finden Sie auf dem Typenschild auf der Rückseite des Gerätes oder auch in der beigelegten Garantie-Registrierkarte.

NEDERLANDS GARANTIE

Voor inlichtingen omtrent garantie dient u zich tot uw plaatselijke **Clearaudio**.

UW KWITANTIE, KASSABON E.D. BEWAREN

Uw kwitantie, kassabon e.d. vormen uw bewijs van aankoop van een waardevol artikel en dienen op een veilige plaats bewaard te worden voor evt, verwijzing bijv, in verbend met verzekering of bij correspondentie met **Clearaudio**.

BELANGRIJK

Bij een evt, beroep op de garantie is het de verantwoordelijkheid van de consument een gedateerd bewijs van aankoop te tonen. Uw kassabon of factuur zijn voldoende bewijs.



ITALIANO GARANZIA

L'apparecchio è coperto da una garanzia di buon funzionamento della durata di un anno, o del periodo previsto dalla legge, a partire dalla data di acquisto comprovata da un documento attestante il nominativo del Rivenditore e la data di vendita. La garanzia sarà prestata con la sostituzione o la riparazione gratuita delle parti difettose. Non sono coperti da garanzia difetti derivanti da uso improprio, errata installazione, manutenzione effettuata da personale non autorizzato o, comunque, da circostanze che non possano riferirsi a difetti di funzionamento dell'apparecchio. Sono inoltre esclusi dalla garanzia gli interventi inerenti l'installazione e l'allacciamento agli impianti di alimentazione.

Gli apparecchi verranno riparati presso i nostri Centri di Assistenza Autorizzati. Le spese ed i rischi di trasporto sono a carico del cliente. La casa costruttrice declina ogni responsabilità per danni diretti o indiretti provocati dalla inosservanza delle prescrizioni di installazione, uso e manutenzione dettagliate nel presente manuale o per guasti dovuti ad uso continuato a fini professionali.

ESPAÑOL GARRANTIA

Para obtener información acerca de la garantía póngase en contacto con su distribuidor **Clearaudio**.

GUARDE SU RECIBO DE COMPRA

Su recibo de compra es su prueba permanente de haber adquirido un aparato de valor, Este recibo deberá guardarlo en un lugar seguro y utilizarlo como referencia cuando tenga que hacer uso del seguro o se ponga en contacto con **Clearaudio**.

IMPORTANTE

Cuando solicite el servicio otorgado por la garantía el usuario tiene la responsabilidad de demostrar cuándo efectuó la compra. En este caso, su recibo de compra será la prueba apropiada.

Stroboscope Testrecord



The **Clearaudio Stroboscope Testrecords** satisfies the highest demands for an exact speed adjustment for turntables. Dramatic sound improvements can be reached only with exact calibrated speeds.

- Optimal adjustment for turntables -



To adjust the exact speed, please choose the side for 50 / 60 Hz, or the other side for the use with the speed light first. If you choose the side without the speed light source, you can use the regular light source for the installation, either 50 Hz (outer scales) or 60 Hz. The scales are graduated in three different reading options: 33.3 Hz, 45 Hz and 78 Hz (starting from the outer diameter).

Please place the *Stroboscope Testrecord* on your turntable platter and start the engine of your turntable. The big advantage of the **Clearaudio Stroboscope Testrecord** is, that you can place your cartridge onto the *Stroboscope Testrecord*, while measuring the speed, as there are grooves provided on the disc. This means, for the first time a real time speed analysis is possible under realistic circumstances.

If you have the impression that the horizontal lines move on the scale, you should set or readjust the speed of the motor again.

- If the lines move clockwise, the speed is too fast.
- If the lines move counter clockwise, the motor speed is too slow.

Please correct the speed on your motor or turntable until you have the impression that the lines stopped moving. After that you have reached the exact speed and you can enjoy the full potential of your vinyl collection again.



If you use the *Speed Light* (Art. No. AC039) you can reach an even higher or more accurate adjustment, completely independent of the power line or frequency of your country. As well, the 300 Hz calibrated light, used as an external light source is completely independent from possible power line fluctuations, which could influence the result by regular light. The 300 Hz of the *Speed Light* are generated by a stabilized quartz oscillator and permit a very exact adjustment. Please put the *Stroboscope Testrecord* with the fine lines upward on your turntable. Here you also have the possibility to choose between two different speeds.

With the outside scale you can detect the speed of 33 Hz and with the inside scale you can detect the speed of 45 Hz. Again, the big advantage of the **Clearaudio Stroboscope Testrecord** is, that you can place your cartridge onto the stroborecord, while measuring the speed, as there are grooves provided on the disc. This means, for the first time a real time speed analysis is possible under realistic circumstances.

Press the button of the *speed light* source and place it parallel over to the scale and adjust the motor or turntable speed until the horizontal lines do not move anymore.

- Tip -

As more accurate your turntable speed is adjusted, as better the overall sonic appearance of the record playback will be!

It is mandatory to check the speed several times through out the year, to ensure that other influences are not minimizing the sound quality.

Technical Data:

Speed Light

Light source: Blue LED / 300 Hz precision light source (calibrated)

Battery: V23GA – 12 V – Alkaline (Art. No.: AC039/B)



Loving music

clearaudio electronic GmbH

Spardorfer Straße 150
91054 Erlangen
Germany

Phone/Tel.: +49 9131 40300 100

Fax: +49 9131 40300 119

www.clearaudio.de

www.analogshop.de

info@clearaudio.de



Handmade in Germany

Clearaudio Electronic accepts no liability for any misprints.

Technical specifications are subject to change or improvement without prior notice.

Product availability is as long as stock lasts.

Copies and reprints of this document, including extracts, require written consent from

Clearaudio Electronic GmbH, Germany.

2025