



**Burson Conductor Voyager (V-280)  
Headphone Amplifier / DAC / Pre Amplifier**

**User Manual**

*Register for warranty Ref. page 11 for details*



## ***Thank You.***

Everyone at Burson Audio wants to say a big thank you and congratulations for buying the Burson Conductor Voyager. We truly think it's a smart choice and that it will give you many years of enjoyment and satisfaction from music.

We know you're excited to start using it, but we suggest getting to know everything your new Burson Conductor Voyager can do first. Please take a moment to read through the manual before turning the device on.



## ***Our Philosophy***

The less the equipment tampers with the music, the greater the purity and musical enjoyment become. This has been the core design philosophy of Burson Audio since 1996. If the equipment is honest and transparent, then the tempo, dynamics and tone will materialize as a natural expression of the music and it becomes unnecessary to 'flavor' the original sound. We believe that this ideal can never be achieved through the use of standard circuitry building blocks such as opamps, IC regulators or even standard transformers. Instead, we work towards this ideal through the research and development of customized solid-state circuitries that are developed specifically to suit our applications, with each and every component being pushed to their performance peak. Only then will the end result be consistent with our philosophy and standards.

***Team Burson***



## Unpacking

After carefully unpacking your Burson Conductor Voyager, inspect for any shipping damage and call your dealer immediately if any is found. Do not power on your Burson Conductor Voyager if you find shipping damage. Please save all packing materials so the unit can be quickly and safely shipped if the need arises.



## The Package

- Conductor Voyager Headphone Amp / Pre Amp / DAC
- External Power Supply 24V 5A
- Remote control unit
- USB Cable
- Mic Adaptor
- 12V trigger cable
- Hex Key / Spare Fuse / Spare IC opamps for troubleshooting.



## Basic Setup

### Four Easy Steps to Setup Your Burson

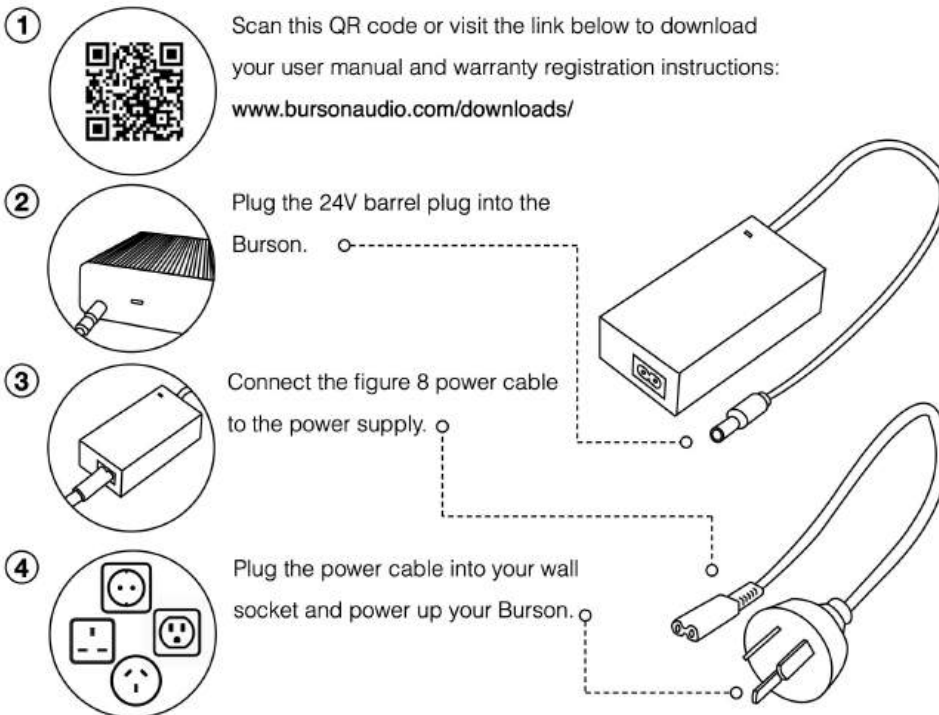



## Connections

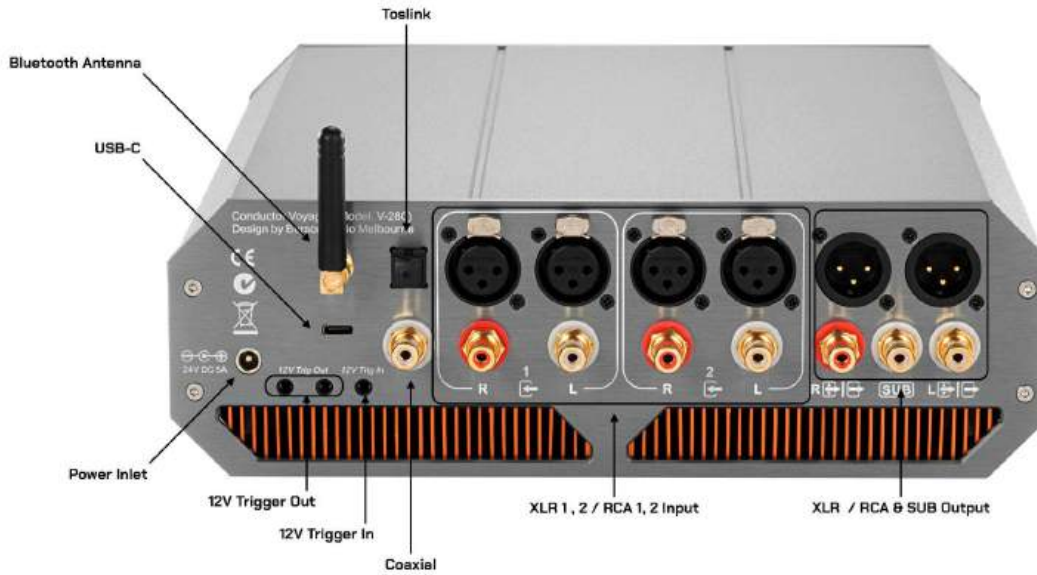



## ***Break-in, Warm-up and Caring***

The sound of the Burson Conductor Voyager improves steadily within minutes of powering up. Depending on the system's resolution and the listener's attentiveness, the sound may continue to improve over the first weeks of operation.

Never connect or disconnect the RCA or XLR output cables from the Conductor Voyager while music is playing. This could damage the Conductor Voyager. Please stop the music source before disconnecting.



## ***Menu Items***

Menu	Options	Comments
Input	USB*	PCM 32bit 786K / DSD512
	Toslink	PCM 24bit 192K
	Coaxial	PCM 24bit 192K
	Bluetooth	PCM 24bit 96K
	RCA 1 & 2	Line level input signal (24bit 192K ADC)
	XLR 1 & 2	Line level input signal (24bit 192K ADC)
Output	Headphone*	Headphone Amp output only
	Headphone + Subwoofer	Headphone + Subwoofer output (no Pre-Amp)
	Pre Out	Pre Amp Out with volume control (Max 12V RMS)
	DAC Out	Line-level RCA @2V RMS XLR @ 4V RMS
	Low	Headphone output power @ 1W
Setting		
Gain Level	High*	Full power (XLR @ 10W / SE @ 5W)
	Low	10% power (XLR @ 1W / SE @ 0.5W) for IEM

FIR Filter	MP*	Minimum Phase
	LPAFR	Linear Phase Apodizing Fast Roll-Off
	MPFRO	Minimum Phase Fast Roll-Off
	MPSRO	Minimum phase slow roll-off
	MPSROLD	Minimum Phase Slow Roll-Off Low Dispersion

The FIR Filter (Finite Impulse Response) defines the digital reconstruction curve of the audio signal. It shapes how the DAC rebuilds the analog waveform from digital data. You can choose between different roll-off types—like fast, slow, or linear phase. Each has a slightly different effect on timing and frequency response. For example, a fast roll-off filter suppresses high-frequency noise more aggressively, while a slow roll-off preserves more high-frequency detail at the expense of slightly more aliasing. It's a tool for fine-tuning the DAC's sonic presentation.

DPLL(BW)	HI* / MID / LOW / OFF	DPLL bandwidth setting
----------	-----------------------	------------------------

The DPLL Bandwidth (Digital Phase-Locked Loop) adjusts how tightly the DAC locks onto incoming digital signals. Lower settings can reduce jitter and improve sound quality but may struggle with unstable or low-quality sources. Higher settings make the DAC more forgiving, especially with Bluetooth or streaming devices.

IRR(BW)	BW / 8	IRR filter bandwidth setting. This changes the default bandwidth value to higher or lower. (refer to SABRE DAC Digital Path below)
	BW / 4	
	BW / 2	
	BW*	
	BW X 2	
	BW X 4	
	IBW X 8	

IRR Bandwidth (Image Rejection Ratio) controls how aggressively the DAC suppresses unwanted out-of-band frequencies—basically digital “noise” that’s outside the audible range. Tweaking this can subtly clean up the background and improve clarity, especially with complex recordings.

DAC PATH	NO BP*	No bypass
	BP IIR	Bypass only IIR stage
	BP FIRX4	Bypass only FIR X 4 filter
	BP FIRX2	Bypass only FIR X 2 filter
	BP ALL	Bypass IIR+ FIR X 2 + FIR X 4

The DAC Path setting changes the internal signal routing inside the ESS chip. It's designed to let you balance between different levels of processing and signal purity. Adjusting this may subtly impact dynamics, tonal balance, and perceived detail, depending on your system.

THD COMP	C2 ON	Only C2 is turn on.
	C2 C3 ON*	By default both C2 and C3 are turn on.
	BP ALL	Bypass both C2 and C3

THD Compensation (Total Harmonic Distortion) is designed to cancel out tiny harmonic distortions introduced during digital-to-analog conversion. Turning it on gives a cleaner, more precise sound. Turning it off may allow a slightly warmer or more relaxed sound, which some listeners prefer.

AUTO OFF	OFF / ON*	Unit auto turn off after 20 mins of no output.
----------	-----------	--

USB MIC	OFF* / ON	USB Mic, turn off allow better compatibility with network streamer and etc.
---------	-----------	---

RESET SET	NO* / YES	
-----------	-----------	--

(\*)= Default factory setting.

FIR Filters are part of the digital process built in the DAC chip. These filter settings mainly affect high-frequency roll-offs usually in the 18khz and above frequency range. The effect of the filter settings is very subtle and may not always be audible.

## Digital FIR Filters:

The ES9039 PRO has pre-programmed digital filters. Burson opened 5, which we believe are relevant to our design, so customers can fine-tune the sound to their liking.

<b>MP</b>	Minimum phase (default)	Less ripple, more image rejection
<b>LPAFR</b>	Liner phase apodizing fast roll-off	Full image rejection by FS/2 to avoid any aliasing, with smooth roll-off starting before 20k
<b>MPFRO</b>	Minimum phase fast roll-off	Low latency, minimal pre-ringing and low passband ripple, image rejection @ 0.55fs
<b>MPSRO</b>	Minimum phase slow roll-off	Lowest latency at the cost of image rejection
<b>MPSROLD</b>	Minimum phase fast roll-off low dispersion	Provides a nice balance of the low latency of minimum phase filters and the low dispersion of linear phase filters. Minimal pre-ringing is added to achieve the low dispersion in the audio band

## Digital Signal Path

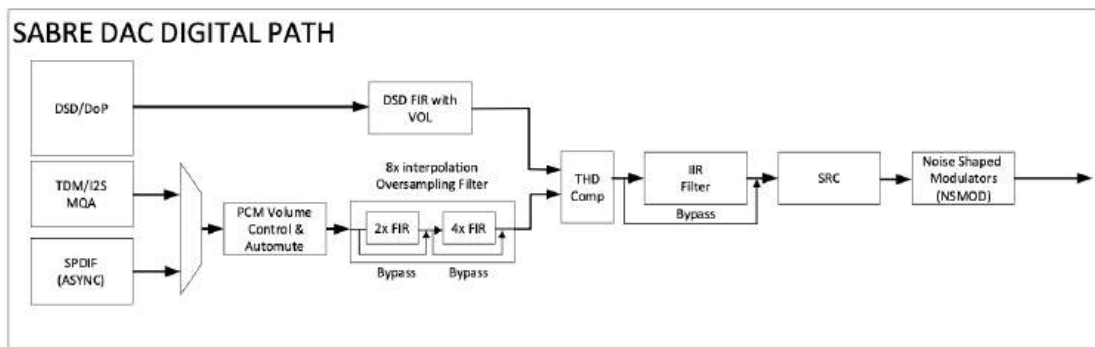

## THD Compensation

The ES9039PRO has built-in THD compensation to help compensate for system second and third harmonics that may be present on the output signal. The compensation is controlled through 4 individual signed 16-bit coefficients in the [THD Compensation Coefficient Registers](#).

The following equation displays how the second and third harmonics are affected by the C2 and C3 values:

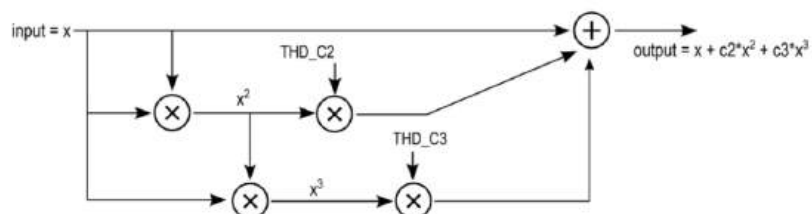

Figure 4 – THD Compensation Block Diagram

For more information on any of the DAC settings, please refer to the official ESS9038 datasheet.



## Changing Menu Items

- To change the menu item settings, press the Menu button to access the Menu.
- Use the rotary Volume control to scroll through the menu items.
- Select a Menu item by pressing the Volume dial inwards.
- Additional choices can be made using the scroll and select function of the Volume dial.
- Press the Menu button to remember the setting and escape from the Menu.



## Opamp Upgrade

To enhance the performance of your Burson device by upgrading the opamp, kindly adhere to the following three simple steps:

Step 1: Prior to changing opamps, ensure that the amplifier is not powered. Safely disconnect the power cable from the back of the unit before proceeding to open the device and make any modifications to its internal circuitry board.



Step 2: It is crucial to note that Dual and Single opamps are distinct and cannot be interchanged. Please refer to the provided layout diagram to determine the number and type of opamps required for your specific machine configuration.

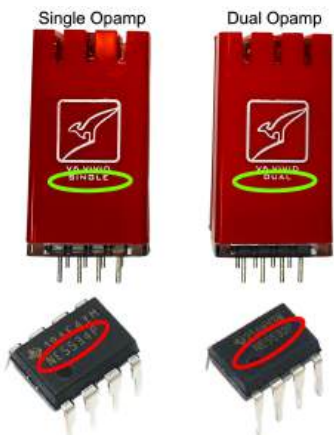
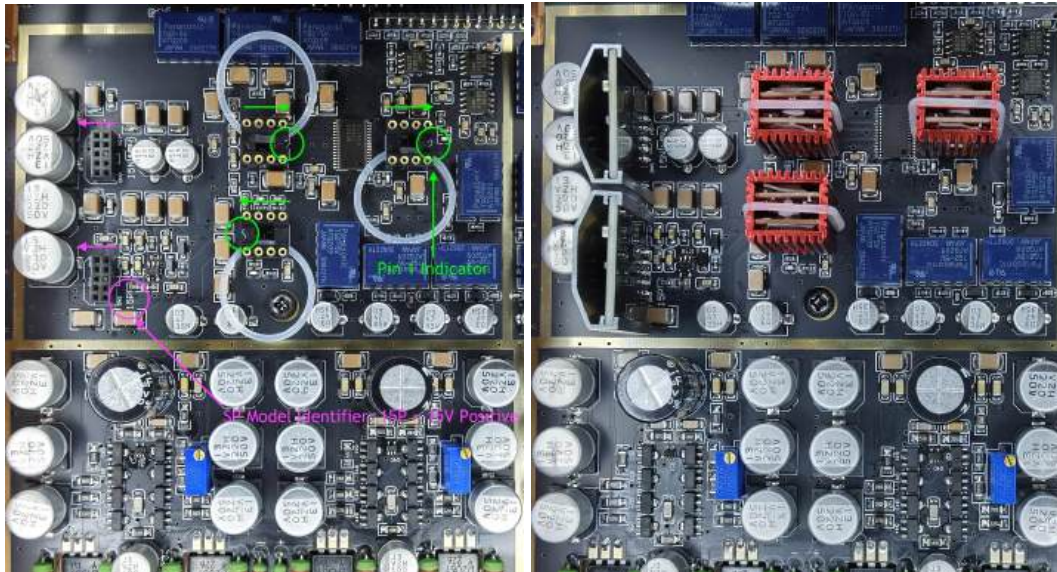

Step 3: Exercise caution while handling opamps, as they are sensitive to polarity. Plugging them in the wrong orientation can result in immediate damage. Identify the pin 1 indicator on the opamp as well as the corresponding half-moon cut on the opamp socket. Before inserting the new opamp, ensure that you have the correct orientation.

**Extra Consideration:** It is essential to recognise that DACs and amplifiers consist of different gain stages, such as the I/V stage, L/P stage, buffer stage, and more. When upgrading opamps, it is advisable to replace all opamps within the same stage simultaneously. For instance, if your

I/V stage currently contains two NE5532 dual opamps and you intend to upgrade them to Burson duals, it is recommended that both NE5532 opamps be replaced at once. This approach ensures the safest and most effective upgrade of your opamps.

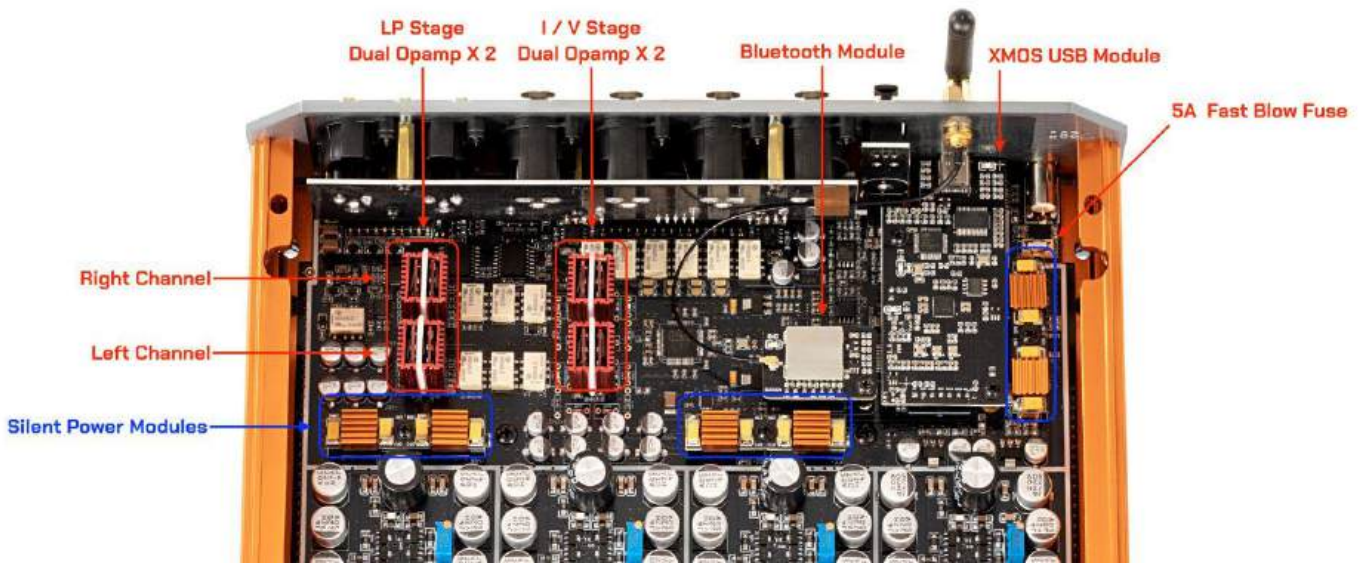

## **Silent Power Module Upgrade**

Upgrading the SP modules even further enhances the performance of Burson products.

The table below shows our variety of SP modules :

When upgrading SP modules, please refer to our diagram or take photos of the default modules so you know where each module should be placed.

1. Identify the correct module you need for your unit. (Refer to the diagram above)
2. Look at the models already installed and compare them to the table below.

Chipset	Noise Spec (10Hz to 100kHz)	Output Voltage	Model
LT1963	40 $\mu$ VRMS	+15V	SP1-15P
LT3015	30 $\mu$ VRMS	-15V	SP1-15N
LT1963	40 $\mu$ VRMS	+5V	SP1-05P
LT1963	40 $\mu$ VRMS	+3.3V	SP1-03P

LT3045	0.8 $\mu$ VRMS	+15V	SP2-15P
LT3094	0.8 $\mu$ VRMS	-15V	SP2-15N
LT3045	0.8 $\mu$ VRMS	+5V	SP2-05P
LT3045	0.8 $\mu$ VRMS	+3.3V	SP2-03P



## ***Fail-safes***

If the fan is disconnected from the motherboard, if the cooling fan fails, or if the Conductor Voyager's top cover is removed, it will automatically go into sleep mode.

Before closing the top cover, please also ensure that cables or other objects do not obstruct the proximity sensor.



## ***Maintenance***

Cleaning the Conductor Voyager may be required if dust accumulates inside.

Please contact our service team to obtain detailed instructions on how to do this.



## ***The Initial Powering up***

Make sure volume control has been turned to minimal when using your Conductor Voyager for the first time. Always power on your source machine first and your power amp last. When powering down your system reverse these steps.

To select the Source - Rotate the Volume dial until the desired input is shown and press inwards to Select.



## ***Free Warranty Extension***

All Burson Audio products are covered by 24 months + 12 months of warranty (See conditions below).

<https://www.bursonaudio.com/warranty/>.



## ***Warranty Conditions***

Burson Audio warrants that this product shall be free from defects in materials and workmanship for The warranty period begins at the date of sale and is subject to the following requirements and understandings:

1. This is a non-transferable warranty.
2. This product is only warranted in the country of original sale by Burson / authorised dealer.
3. The product must not have been modified in any manner whatsoever, or the warranty is immediately voided.
4. The product must not have been stored in a humid, damp environment; nor subjected to weather, water, or salt spray.
5. During the warranty period, Burson will replace a defective Burson Conductor Voyager with a similar available product, at no cost to the owner for labour, materials, and shipping charges from Burson.
6. Burson shall not, under any circumstances, be liable for any incidental or consequential damages arising from the loss of property or other damage or losses due to the failure of a Burson Conductor Voyager. Burson will not pay for loss of use or inconvenience caused by the failure of a Burson Conductor Voyager. Burson will not pay for damage caused to other audio components caused by the failure of the Burson Conductor Voyager within the limits allowed by Australian Law.
7. The compatibility between our USB receiver and your computer is dependent on software drivers provided to Burson by the USB chip manufacturer. Therefore Burson cannot guarantee the compatibility of our USB receiver during or after the warranty period.
8. The use of XLR to RCA adaptors will void the warranty.



Warranty Registration